



# MODEL T10041 HI-LIFT HYDRAULIC CART INSTRUCTION SHEET

## Introduction

The Model T10041 Hi-Lift Hydraulic Cart (**Figure 1**) will move and raise material weighing up to 330 lbs. to a maximum working height of 53¼" above the floor.

The Model T10041 was carefully packed when it left our warehouse. If you discover this Hi-Lift Hydraulic Cart is damaged after you have signed for delivery, *please immediately call Customer Service at (570) 546-9663 for advice.*

Save the containers and all packing materials for possible inspection by the carrier or its agent. *Otherwise, filing a freight claim can be difficult.*

When you are completely satisfied with the condition of your shipment, you should inventory the contents.

### Inventory (Figure 2)

- A. Cart (Not Shown) ..... 1
- B. Handle ..... 1
- C. Foot Pedal ..... 1
- D. Hex Bolts M8-1.25 x 40 (Handle) ..... 2
- E. Hex Bolt M8-1.25 x 20 (Foot Pedal) ..... 1



Figure 1. Hi-Lift Hydraulic Cart.

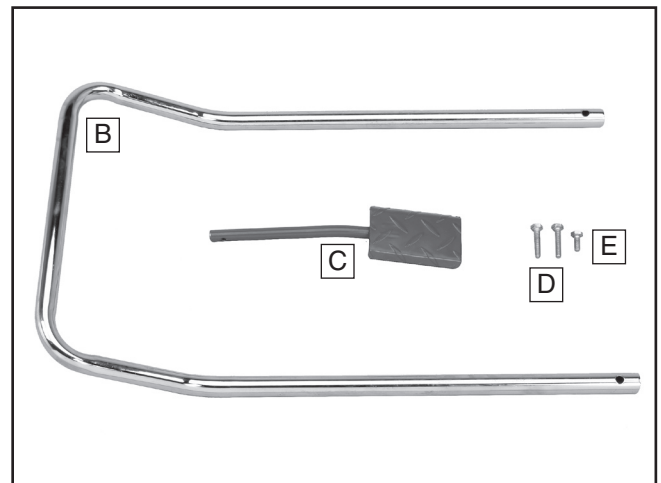

Figure 2. Inventory.

### **!WARNING**

This table cart is not a toy. **DO NOT** allow children to use this cart. Serious injury may occur if this cart is used incorrectly.

### **!WARNING**

This table cart is not designed to support people or to be used as a lift for working beneath. Serious injury may occur if this cart is used incorrectly.

COPYRIGHT © OCTOBER, 2007 BY GRIZZLY INDUSTRIAL, INC.

**WARNING: NO PORTION OF THIS MANUAL MAY BE REPRODUCED IN ANY SHAPE OR FORM WITHOUT THE WRITTEN APPROVAL OF GRIZZLY INDUSTRIAL, INC.**

#JB10054 PRINTED IN CHINA

# Assembly

## To assemble the cart:

1. Slide the lifting pedal into the pedal shaft and secure in place with the M8-1.25 x 20 hex bolt as shown in **Figure 3**.
2. Place the handle in the handle sockets and secure with the M8-1.25 x 40 hex bolts (**Figure 3**).

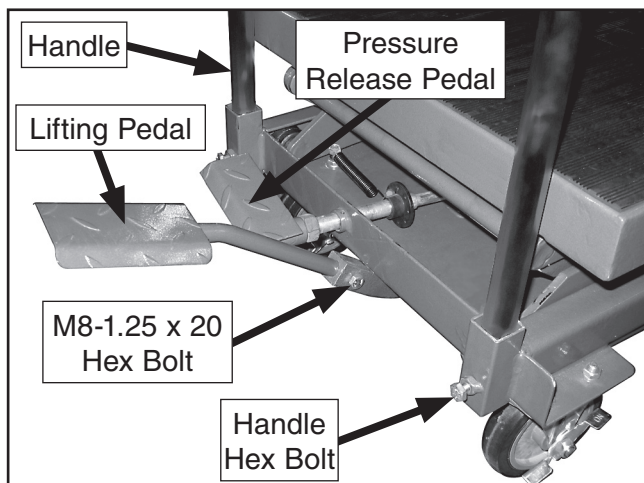

**Figure 3.** Assembly.

## **!WARNING**

### To reduce the risk of serious personal injury when using this equipment:

- Keep hands out of the scissor lift to prevent serious pinching and crushing injuries.
- DO NOT exceed the 330 lb. load capacity.
- Lock the casters when loading and unloading the cart.
- Balance the load evenly in the center of the cart.
- Transport the load in the fully lowered position to prevent tipping.

# Operations



- Lock casters whenever the cart is stationary.
- Balance the load evenly in the center of the cart.
- Pump the lifting pedal to raise the table.
- Push the pressure release pedal to lower the table (**Figure 3**).

**Note:** Always lower the table when not in use.

# Maintenance

- Fully lower the tabletop when not in use.
- Wipe all dirt and dust off the table cart.
- Apply light oil to the surface of the hydraulic jack ram.
- If the lifting pedal fails to raise the table, remove the plug on the top of the hydraulic jack. Add oil until full, replace the plug, then pump the handle several times with the pressure release valve open to bleed the air out of the system.

*If you need additional help with this procedure, call our service department at: (570) 546-9663.*



# Parts & Warning Labels Breakdown and List

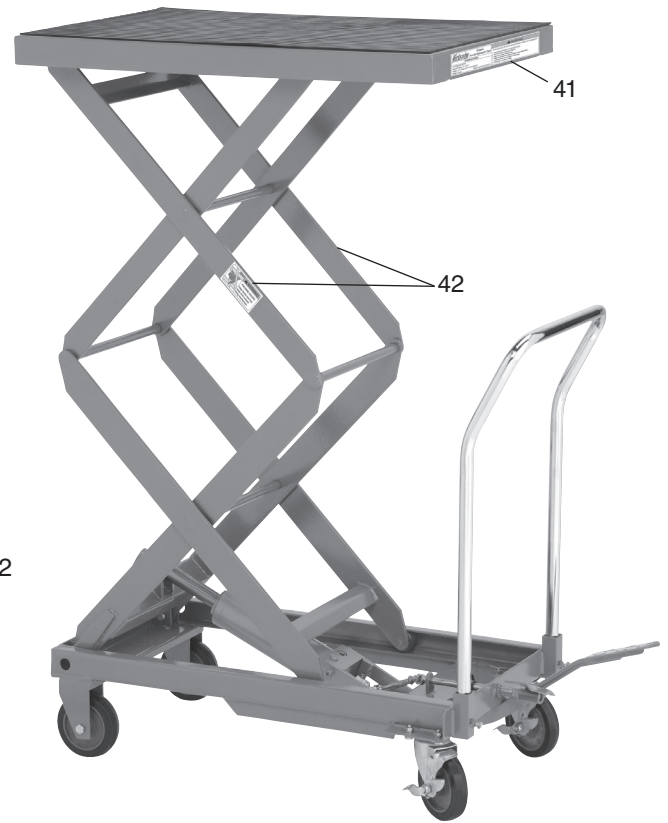
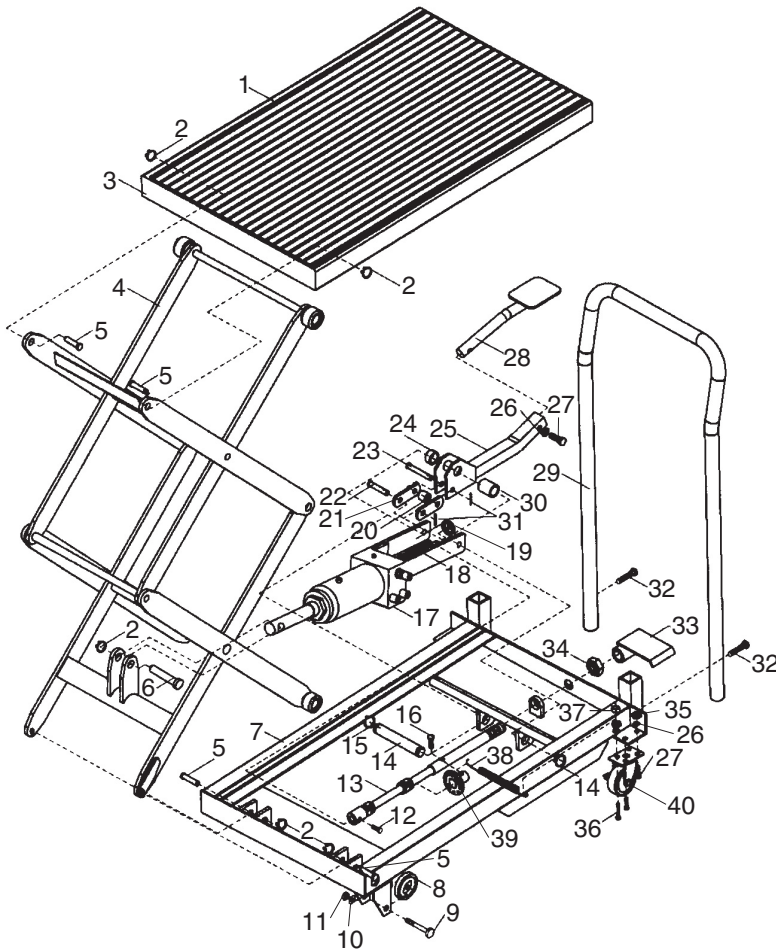

REF	PART #	DESCRIPTION
1	PT10041001	RUBBER MAT
2	PR06M	EXT RETAINING RING 16MM
3	PT10041003	TABLE TOP
4	PT10041004	LIFT FRAME
5	PT10041005	CLEVIS PIN 16 X 55
6	PT10041006	CLEVIS PIN 16 X 65
7	PT10041007	BASE ASSEMBLY
8	PT10041008	FRONT WHEEL
9	PB120M	HEX BOLT M10-1.5 X 65
10	PW04M	FLAT WASHER 10MM
11	PN02M	HEX NUT M10-1.5
12	PB107M	HEX BOLT M5-.8 X 12
13	PT10041013	PRESSURE RELIEF SHAFT
14	PT10041014	JACK PIN
15	PR09M	EXT RETAINING RING 20MM
16	PB02M	HEX BOLT M6-1 X 12
17	PT10041017	JACK
18	PT10041018	COMPRESSION SPRING
19	PT10041019	SPRING CAP
20	PT10041020	SPACER
21	PT10041021	CONNECTING PLATE

REF	PART #	DESCRIPTION
22	PT10041022	CLEVIS PIN 10 X 35
23	PT10041023	CLEVIS PIN 10 X 45
24	PT10041024	SHORT SPACER
25	PT10041025	PEDAL SHAFT
26	PLW04M	LOCK WASHER 8MM
27	PB09M	HEX BOLT M8-1.25 X 20
28	PT10041028	LIFTING PEDAL
29	PT10041029	HANDLE
30	PT10041030	LONG SPACER
31	PT10041031	COTTER PIN 2 X 20
32	PB126M	HEX BOLT M8-1.25 X 40
33	PT10041033	PRESSURE RELIEF PEDAL
34	PN13M	HEX NUT M16-2
35	PN03M	HEX NUT M8-1.25
36	PB26M	HEX BOLT M8-1.25 X 30
37	PLN04M	LOCK NUT M8-1.25
38	PT10041038	EXTENSION SPRING
39	PT10041039	SPRING COLLAR
40	PT10041040	REAR WHEEL
41	PT10041041	MACHINE ID LABEL
42	PT10041042	SCISSOR LIFT WARNING



# *grizzly.com*

**TOOL WEBSITE**

Buy Direct and Save with Grizzly® – Trusted, Proven and a Great Value!

*Visit Our Website Today And Discover  
Why Grizzly® Is The Industry Leader!*

- SECURE ORDERING
- ORDERS SHIPPED WITHIN 24 HOURS
- E-MAIL RESPONSE WITHIN ONE HOUR

-OR-

Call Today For A **FREE**  
Full Color Catalog

**1-800-523-4777**

